

(19) World Intellectual Property Organization  
International Bureau



INTERNATIONAL BUREAU OF PATENT COOPERATION  
3, rue de la Harpe, 75001 Paris, France  
P.O. Box 6859, Geneva, Switzerland  
4800, rue de la Corniche, 1203 Geneva, Switzerland  
Patent Cooperation Treaty Secretariat  
P.O. Box 18, 2511 Yverdon, Switzerland

(43) International Publication Date  
11 July 2002 (11.07.2002)

PCT

(10) International Publication Number  
WO 02/053867 A3

- (51) International Patent Classification<sup>7</sup>: E21B 43/10, 19/00
- (21) International Application Number: PCT/US02/00093
- (22) International Filing Date: 2 January 2002 (02.01.2002)
- (25) Filing Language: English
- (26) Publication Language: English
- (30) Priority Data: 60/259,486 3 January 2001 (03.01.2001) US
- (71) Applicant (for all designated States except US): ENVEN-  
TURE GLOBAL TECHNOLOGY [US/US]; 16200 A  
Park Row, Houston, TX 77084 (US).
- (72) Inventors; and
- (75) Inventors/Applicants (for US only): COOK, Robert,

Lance [US/US]; 934 Caswell Court, Katy, TX 77450 (US).  
RING, Lev [RU/US]; 14126 Heatherhill Place, Houston,  
TX 77077 (US). ZWALD, Ed [US/US]; Memorial Drive  
#110, Houston, TX 77024 (US). FILLIPOV, Andrei  
[US/US]; 2606 Hidden Shore Drive, Katy, TX 77450 (US).  
WADELL, Kevin [US/US]; 11007 Sprucedale Court,  
Houston, TX 77070 (US).

(74) Agents: MATTINGLY, Todd et al.; Haynes and Boone,  
LLP, 1000 Louisiana, Suite 4300, Houston, TX 77002-  
5012 (US).

(81) Designated States (national): AE, AG, AL, AM, AT, AU,  
AZ, BA, BB, BG, BR, BY, BZ, CA, CH, CN, CO, CR, CU,  
CZ, DE, DK, DM, DZ, EE, ES, FI, GB, GD, GE, GH, GM,  
HR, HU, ID, IL, IN, IS, JP, KE, KG, KP, KR, KZ, LC, LK,  
LR, LS, LT, LU, LV, MA, MD, MG, MK, MN, MW, MX,  
MZ, NO, NZ, OM, PH, PL, PT, RO, RU, SD, SE, SG, SI,  
SK, SL, TJ, TM, TN, TR, TT, TZ, UA, UG, US, UZ, VN,  
YU, ZA, ZM, ZW.

[Continued on next page]

(54) Title: MONO-DIAMETER WELLBORE CASING

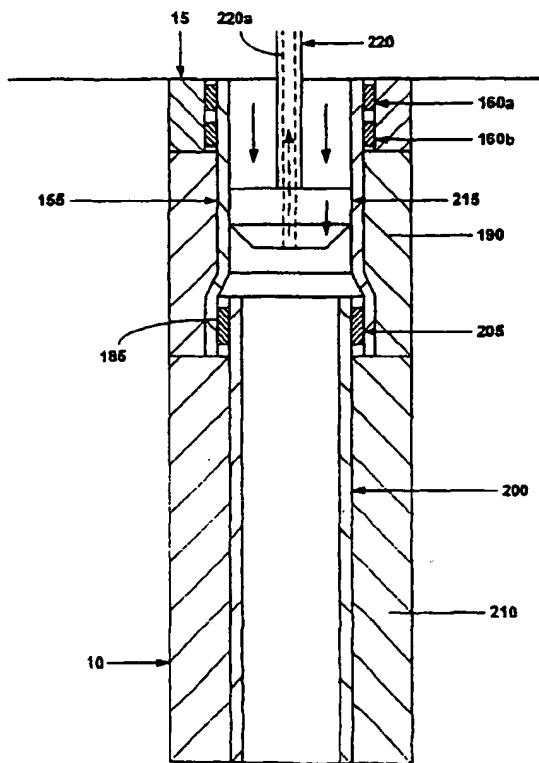

(57) Abstract: Plastically deforming and radially expanding a first tubular member (155) within a wellbore (10) form a mono-diameter wellbore casing. A second tubular member (200) is then plastically deformed and radially expanded, overlapping the first tubular member (155). Then the second tubular (200) and the overlapped portion of the first tubular (155) are expanded.



WO 02/053867 A3

(84) Designated States (*regional*): ARIPO patent (GH, GM, KE, LS, MW, MZ, SD, SL, SZ, TZ, UG, ZM, ZW), Eurasian patent (AM, AZ, BY, KG, KZ, MD, RU, TJ, TM), European patent (AT, BE, CH, CY, DE, DK, ES, FI, FR, GB, GR, IE, IT, LU, MC, NL, PT, SE, TR), OAPI patent (BF, BJ, CF, CG, CI, CM, GA, GN, GQ, GW, ML, MR, NE, SN, TD, TG).

(88) Date of publication of the international search report:  
6 February 2003

Date of publication of the amended claims: 3 April 2003

*For two-letter codes and other abbreviations, refer to the "Guidance Notes on Codes and Abbreviations" appearing at the beginning of each regular issue of the PCT Gazette.*

**Declaration under Rule 4.17:**

— *of inventorship (Rule 4.17(iv)) for US only*

**Published:**

— *with international search report*

— *with amended claims*

## AMENDED CLAIMS

[received by the International Bureau on 3 October 2002 (03.10.02);  
original claims 9-12, 21, 29, 46-49, 60, 72, 85, 90, 94, 99, 106-108, 122-124, 144 and 145 amended;  
remaining claims unchanged (18 pages)]

9. An apparatus for plastically deforming and radially expanding a tubular member, comprising:
- a tubular support member including a first fluid passage;
  - an expansion member comprising an external surface for plastically deforming and radially expanding the tubular member coupled to the tubular support member having a second fluid passage fluidically coupled to the first fluid passage;
  - a removable annular sleeve comprising an external surface for plastically deforming and radially expanding the tubular member coupled to the external surface of the expansion member;
  - an annular expansion member launcher coupled to the annular sleeve and a lower portion of the tubular member; and
  - a shoe having a valveable passage coupled to an end of the expansion member launcher.
10. (Amended) The apparatus of claim 9, wherein the annular sleeve is frangible.
11. (Amended) The apparatus of claim 9, wherein the annular sleeve is elastic.
12. (Amended) The apparatus of claim 9, wherein the annular sleeve comprises a plurality of arcuate elements.
13. A method of plastically deforming and radially expanding a tubular member, comprising:
- plastically deforming and radially expanding a portion of the tubular member to a first outside diameter; and
  - plastically deforming and radially expanding another portion of the tubular member to a second outside diameter.
14. The method of claim 13, wherein the first diameter is greater than the second diameter.

15. The method of claim 13, wherein plastically deforming and radially expanding the portion of the tubular member comprises:

applying a radial force to the portion of the tubular member using a conical sleeve.

16. The method of claim 15, wherein the conical sleeve is frangible.
17. The method of claim 15, wherein the conical sleeve is elastic.
18. The method of claim 15, wherein the conical sleeve comprises a plurality of arcuate elements.
19. The method of claim 13, wherein plastically deforming and radially expanding the portion of the tubular member comprises:  
applying a radial force to the portion of the tubular member using an inflatable bladder.
20. The method of claim 13, wherein plastically deforming and radially expanding the portion of the tubular member comprises:  
applying a radial force to the portion of the tubular member using a roller expansion device.
21. (Amended) A method of coupling a first tubular member to a second tubular member, comprising:  
plastically deforming and radially expanding a first portion of the first tubular member to a first outside diameter;  
plastically deforming and radially expanding another portion of the first tubular member to a second outside diameter;  
positioning the second tubular member inside the first tubular member in overlapping relation to the first portion of the first tubular member;  
plastically deforming and radially expanding the second tubular member to a third outside diameter; and  
plastically deforming and radially expanding the second tubular member to a fourth outside diameter;  
wherein the first and second tubular members after the plastic deformations and radial expansions define a passageway having a substantially constant cross sectional area.

22. The method of claim 21, wherein the first outside diameter is greater than the second outside diameter.
23. The method of claim 21, wherein plastically deforming and radially expanding the first portion of the first tubular member comprises:  
applying a radial force to the portion of the tubular member using a conical sleeve.
24. The method of claim 23, wherein the conical sleeve is frangible.
25. The method of claim 23, wherein the conical sleeve is elastic.
26. The method of claim 23, wherein the conical sleeve comprises a plurality of arcuate elements.
27. The method of claim 21, wherein plastically deforming and radially expanding the first portion of the first tubular member comprises:  
applying a radial force to the first portion of the first tubular member using an inflatable bladder.
28. The method of claim 21, wherein plastically deforming and radially expanding the first portion of the first tubular member comprises:  
applying a radial force to the first portion of the first tubular member using a roller expansion device.
29. (Amended) An apparatus for coupling a first tubular member to a second tubular member, comprising:  
means for plastically deforming and radially expanding a first portion of the first tubular member to a first outside diameter;  
means for plastically deforming and radially expanding another portion of the first tubular member to a second outside diameter;  
means for positioning the second tubular member inside the first tubular member in overlapping relation to the first portion of the first tubular member;  
means for plastically deforming and radially expanding the second tubular member to a third outside diameter; and

means for plastically deforming and radially expanding the second tubular member to a fourth outside diameter;

wherein the first and second tubular members after the plastic deformations and radial expansions define a passageway having a substantially constant cross sectional area.

30. The apparatus of claim 29, wherein the first outside diameter is greater than the second outside diameter.

31. The apparatus of claim 29, wherein the means for plastically deforming and radially expanding the first portion of the first tubular member comprises:  
means for applying a radial force to the portion of the tubular member using a conical sleeve.

32. The apparatus of claim 31, wherein the conical sleeve is frangible.

33. The apparatus of claim 31, wherein the conical sleeve is elastic.

34. The apparatus of claim 31, wherein the conical sleeve comprises a plurality of arcuate elements.

35. The apparatus of claim 29, wherein the means for plastically deforming and radially expanding the first portion of the first tubular member comprises:  
means for applying a radial force to the first portion of the first tubular member using an inflatable bladder.

36. The apparatus of claim 29, wherein the means for plastically deforming and radially expanding the first portion of the first tubular member comprises:  
means for applying a radial force to the first portion of the first tubular member using a roller expansion device.

comprises rolling means for applying radial pressure to the first portion of the tubular member.

45. The apparatus of claim 37, further comprising:  
means for forming an annular body of a fluidic sealing material within an annulus between the tubular member and the wellbore.
46. (Amended) An apparatus for forming a wellbore casing within a wellbore, comprising:  
a tubular support member including a first fluid passage;  
an expansion member coupled to the tubular support member having a second fluid passage fluidically coupled to the first fluid passage and an outer surface for radially expanding and plastically deforming the wellbore casing;  
a removable annular sleeve comprising an outer surface for radially expanding and plastically deforming the wellbore casing coupled to the outer surface of the expansion member;  
an annular expansion member launcher coupled to the annular sleeve and a lower portion of the wellbore casing; and  
a shoe having a valveable passage coupled to an end of the expansion member launcher.
47. (Amended) The apparatus of claim 46, wherein the annular sleeve is frangible.
48. (Amended) The apparatus of claim 46, wherein the annular sleeve is elastic.
49. (Amended) The apparatus of claim 46, wherein the annular sleeve comprises a plurality of arcuate elements.
50. A method of forming a wellbore casing within a wellbore, comprising:  
supporting a tubular member within a wellbore;  
plastically deforming and radially expanding a portion of the tubular member to a first outside diameter; and  
plastically deforming and radially expanding another portion of the tubular member to a second outside diameter.



51. The method of claim 50, wherein the first diameter is greater than the second diameter.
52. The method of claim 50, wherein plastically deforming and radially expanding the portion of the tubular member comprises:  
applying a radial force to the portion of the tubular member using a conical sleeve.
53. The method of claim 50, wherein the conical sleeve is frangible.
54. The method of claim 50, wherein the conical sleeve is elastic.
55. The method of claim 50, wherein the conical sleeve comprises a plurality of arcuate elements.
56. The method of claim 50, wherein plastically deforming and radially expanding the portion of the tubular member comprises:  
applying a radial force to the portion of the tubular member using an inflatable bladder.
57. The method of claim 50, wherein plastically deforming and radially expanding the portion of the tubular member comprises:  
applying a radial force to the portion of the tubular member using a roller expansion device.
58. The method of claim 50, further comprising:  
injecting an annular body of a hardenable fluidic sealing material into an annulus between the tubular member and the wellbore.
59. The method of claim 58, further comprising:  
curing the annular body of hardenable fluidic sealing material.
60. (Amended) A method of forming a mono-diameter wellbore casing within a wellbore, comprising:

supporting a first tubular member within the wellbore;  
plastically deforming and radially expanding a first portion of the first tubular member to a first outside diameter;  
plastically deforming and radially expanding another portion of the first tubular member to a second outside diameter;  
positioning the second tubular member inside the first tubular member in overlapping relation to the first portion of the first tubular member;  
plastically deforming and radially expanding the second tubular member to a third outside diameter; and  
plastically deforming and radially expanding the second tubular member to a fourth outside diameter;

wherein the first and second tubular members after the plastic deformations and radial expansions define a passageway having a substantially constant cross sectional area.

61. The method of claim 60, wherein the first outside diameter is greater than the second outside diameter.
62. The method of claim 60, wherein plastically deforming and radially expanding the first portion of the first tubular member comprises:  
applying a radial force to the portion of the tubular member using a conical sleeve.
63. The method of claim 62, wherein the conical sleeve is frangible.
64. The method of claim 62, wherein the conical sleeve is elastic.
65. The method of claim 62, wherein the conical sleeve comprises a plurality of arcuate elements.
66. The method of claim 60, wherein plastically deforming and radially expanding the first portion of the first tubular member comprises:  
applying a radial force to the first portion of the first tubular member using an inflatable bladder.

67. The method of claim 60, wherein plastically deforming and radially expanding the first portion of the first tubular member comprises:  
applying a radial force to the first portion of the first tubular member using a roller expansion device.
68. The method of claim 60, further comprising:  
injecting an annular body of a hardenable fluidic sealing material into an annulus between the first tubular member and the wellbore.
69. The method of claim 68, further comprising:  
curing the annular body of hardenable fluidic sealing material.
70. The method of claim 60, further comprising:  
injecting an annular body of a hardenable fluidic sealing material into an annulus between the second tubular member and the wellbore.
71. The method of claim 70, further comprising:  
curing the annular body of hardenable fluidic sealing material.
72. (Amended) An apparatus for coupling a first tubular member to a second tubular member, comprising:  
means for plastically deforming and radially expanding a first portion of the first tubular member to a first outside diameter;  
means for plastically deforming and radially expanding another portion of the first tubular member to a second outside diameter;  
means for positioning the second tubular member inside the first tubular member in overlapping relation to the first portion of the first tubular member;  
means for plastically deforming and radially expanding the second tubular member to a third outside diameter; and  
means for plastically deforming and radially expanding the second tubular member to a fourth outside diameter;  
wherein the first and second tubular members after the plastic deformations and radial expansions define a passageway having a substantially constant cross sectional area.

84. An apparatus for plastically deforming and radially expanding a tubular member, comprising:

means for providing a lipped portion in a portion of the tubular member; and  
means for plastically deforming and radially expanding another portion of the tubular member.

85. (Amended) An apparatus for plastically deforming and radially expanding a tubular member, comprising:

a tubular support member including a first fluid passage;  
an expansion member coupled to the tubular support member having a second fluid passage fluidically coupled to the first fluid passage and an outer surface for radially expanding and plastically deforming the tubular member;

an annular expansion member launcher comprising:

a first annular portion coupled to a lower portion of the tubular member;  
a second annular portion coupled to the first annular portion that mates with the outer surface of the expansion member;  
a third annular portion coupled to the second annular portion having a first outside diameter; and  
a fourth annular portion coupled to the third annular portion having a second outside diameter;

wherein the second outside diameter is less than the first outside diameter; and a shoe having a valveable passage coupled to fourth annular portion of the expansion member launcher.

86. A method of plastically deforming and radially expanding a tubular member, comprising:

providing a lipped portion in a portion of the tubular member; and  
plastically deforming and radially expanding another portion of the tubular member.

87. A method of coupling a first tubular member to a second tubular member, comprising:

providing a lipped portion in a portion of the first tubular member;

plastically deforming and radially expanding another portion of the first tubular member;  
positioning the second tubular member inside the first tubular member in overlapping relation to the lipped portion of the first tubular member; and  
plastically deforming and radially expanding the second tubular member;  
wherein the inside diameters of the first and second tubular members after the plastic deformations and radial expansions are substantially equal.

88. An apparatus for coupling a first tubular member to a second tubular member, comprising:

means for providing a lipped in the first tubular member;  
means for plastically deforming and radially expanding another portion of the first tubular member;  
means for positioning the second tubular member inside the first tubular member in overlapping relation to the lipped portion of the first tubular member; and  
means for plastically deforming and radially expanding the second tubular member;  
wherein the inside diameters of the first and second tubular members after the plastic deformations and radial expansions are substantially equal.

89. An apparatus for forming a wellbore casing within a wellbore, comprising:

means for supporting a tubular member within the wellbore;  
means for providing a lipped portion in the tubular member; and  
means for plastically deforming and radially expanding another portion of the tubular member to a second outside diameter.

90. (Amended) An apparatus for forming a wellbore casing within a wellbore, comprising:

a tubular support member including a first fluid passage;  
an expansion member coupled to the tubular support member having a second fluid passage fluidically coupled to the first fluid passage and an outer surface for radially expanding and plastically deforming the wellbore casing;  
an annular expansion member launcher comprising:

a first annular portion coupled to a lower portion of the wellbore casing;  
a second annular portion coupled to the first annular portion that mates with  
the outer surface of the expansion member;  
a third annular portion coupled to the second annular portion having a first  
outside diameter; and  
a fourth annular portion coupled to the third annular portion having a  
second outside diameter;  
wherein the second outside diameter is less than the first outside diameter;  
and a shoe having a valveable passage coupled to fourth annular portion of the expansion  
member launcher.

91. A method of forming a wellbore casing in a wellbore, comprising:  
supporting a tubular member within the wellbore;  
providing a lipped portion in a portion of the tubular member; and  
plastically deforming and radially expanding another portion of the tubular  
member.
92. The method of claim 91, further comprising:  
injecting a hardenable fluidic sealing material in an annulus between the tubular  
member and the wellbore.
93. The method of claim 92, further comprising:  
curing the fluidic sealing material.
94. (Amended) A method of forming a mono-diameter wellbore casing within a wellbore,  
comprising:  
supporting a first tubular member within the wellbore;  
providing a lipped portion in a portion of the first tubular member;  
plastically deforming and radially expanding another portion of the first tubular  
member;  
positioning the second tubular member inside the first tubular member in  
overlapping relation to the lipped portion of the first tubular member; and  
plastically deforming and radially expanding the second tubular member;

wherein the first and second tubular members after the plastic deformations and radial expansions define a passageway having a substantially constant cross sectional area.

95. The method of claim 94, further comprising:  
injecting a hardenable fluidic sealing material in an annulus between the first tubular member and the wellbore.
96. The method of claim 95, further comprising:  
curing the fluidic sealing material.
97. The method of claim 94, further comprising:  
injecting a hardenable fluidic sealing material in an annulus between the second tubular member and the wellbore.
98. The method of claim 97, further comprising:  
curing the fluidic sealing material.
99. (Amended) An apparatus for forming a mono-diameter wellbore casing within a wellbore, comprising:  
means for providing a lipped in the first tubular member;  
means for plastically deforming and radially expanding another portion of the first tubular member;  
means for positioning the second tubular member inside the first tubular member in overlapping relation to the lipped portion of the first tubular member; and  
means for plastically deforming and radially expanding the second tubular member;  
wherein the first and second tubular members after the plastic deformations and radial expansions define a passageway having a substantially constant cross sectional area.
100. The apparatus of claim 99, further comprising:  
means for injecting a hardenable fluidic sealing material in an annulus between the first tubular member and the wellbore.

104. An apparatus for plastically deforming and radially expanding a tubular member, comprising:  
means for plastically deforming and radially expanding a first end of the tubular member;  
and  
means for plastically deforming and radially expanding a second end of the tubular member.
105. The apparatus of claim 104, further comprising:  
means for anchoring the tubular member during the radial expansion.
106. (Amended) An apparatus for plastically deforming and radially expanding a tubular member, comprising:  
a tubular support member including a first passage;  
an expansion member coupled to the tubular support member having a second passage fluidly coupled to the first passage and an outer surface for radially expanding and plastically deforming the tubular member;  
an annular expansion member launcher movably coupled to the outer surface of the expansion member and coupled to an end of the tubular member;  
a shoe coupled to another end of the annular expansion member launcher having a valveable fluid passage; and  
another annular expansion member comprising an outer surface for radially expanding and plastically deforming the tubular member movably coupled to the tubular support member;  
wherein the annular expansion members are positioned in opposite orientations.
107. (Amended) The apparatus of claim 106, wherein the annular expansion member is adapted to plastically deform and radially expand a first end of the tubular member and the other annular expansion member is adapted to plastically deform and radially expand a second end of the tubular member.
108. (Amended) The apparatus of claim 106, further comprising:  
an anchoring member coupled to the tubular support member adapted to hold the tubular member.



means for positioning the second tubular member inside the first tubular member in an overlapping relationship;

means for plastically deforming and radially expanding the end of the second tubular member that overlaps with the first tubular member;

means for plastically deforming and radially expanding the remaining portion of the second tubular member

117. The apparatus of claim 116, further comprising:

means for plastically deforming and radially expanding at least a portion of the second tubular member.

118. The apparatus of claim 117, wherein the inside diameters of the first and second tubular members are substantially equal after the radial expansions.

119. An apparatus for forming a wellbore casing within a wellbore, comprising:

means for supporting a tubular member within the wellbore;

means for plastically deforming and radially expanding a first end of the tubular member; and

means for plastically deforming and radially expanding a second end of the tubular member.

120. The apparatus of claim 119, further comprising:

means for anchoring the tubular member during the radial expansion.

121. The apparatus of claim 119, further comprising:

means for injecting a hardenable fluidic sealing material into an annulus between the tubular member and the wellbore.

122. (Amended) An apparatus for forming a wellbore casing within a wellbore, comprising:

a tubular support member including a first passage;

an expansion member coupled to the tubular support member having a second passage fluidically coupled to the first passage and an outer surface for radially expanding and plastically deforming the wellbore casing;  
an annular expansion member launcher movably coupled to the outer surface of the expansion member and coupled to an end of the wellbore casing;  
a shoe coupled to another end of the annular expansion member launcher having a valveable fluid passage; and  
another annular expansion member movably coupled to the tubular support member comprising an outer surface for radially expanding and plastically deforming the wellbore casing;  
wherein the annular expansion members are positioned in opposite orientations.

123. (Amended) The apparatus of claim 122, wherein the annular expansion member is adapted to plastically deform and radially expand a first end of the wellbore casing and the other annular expansion member is adapted to plastically deform and radially expand a second end of the wellbore casing.

124. (Amended) The apparatus of claim 122, further comprising: an anchoring member coupled to the tubular support member adapted to hold the wellbore casing.

125. A method of forming a wellbore casing within a wellbore, comprising:  
plastically deforming and radially expanding a first end of the tubular member; and  
plastically deforming and radially expanding a second end of the tubular member.

126. The method of claim 125, further comprising: anchoring the tubular member during the radial expansion.

127. The method of claim 125, wherein the first end of the tubular member is plastically deformed and radially expanded before the second end.

128. The method of claim 125, plastically deforming and radially expanding the second end of the tubular member comprises injecting a fluidic material into the tubular member.

129. The method of claim 125, further comprising:

144. (Amended) A method of coupling a first tubular member to a second tubular member, the first tubular member having an original outside diameter  $OD_0$  and an original wall thickness  $t_0$ , comprising:

plastically deforming and radially expanding a first portion of the first tubular member to a first outside diameter;

plastically deforming and radially expanding another portion of the first tubular member to a second outside diameter;

positioning the second tubular member inside the first tubular member in overlapping relation to the first portion of the first tubular member;

plastically deforming and radially expanding the second tubular member to a third outside diameter; and

plastically deforming and radially expanding the second tubular member to a fourth outside diameter;

wherein the first and second tubular members after the plastic deformations and radial expansions define a passageway having a substantially constant cross sectional area; and

wherein the ratio of the original outside diameter  $OD_0$  of the first tubular member to the original wall thickness  $t_0$  of the first tubular member is greater than or equal to 16.

145. (Amended) A method of forming a mono-diameter wellbore casing, comprising:

positioning a first tubular member within a wellbore, the first tubular member having an original outside diameter  $OD_0$  and an original wall thickness  $t_0$ ;

plastically deforming and radially expanding a first portion of the first tubular member to a first outside diameter;

plastically deforming and radially expanding another portion of the first tubular member to a second outside diameter;

positioning the second tubular member inside the first tubular member in overlapping relation to the first portion of the first tubular member;

plastically deforming and radially expanding the second tubular member to a third outside diameter; and

plastically deforming and radially expanding the second tubular member to a fourth outside diameter;

wherein the first and second tubular members after the plastic deformations and radial expansions define a passageway having a substantially constant cross sectional area; and

wherein the ratio of the original outside diameter  $OD_0$  of the first tubular member to the original wall thickness  $t_0$  of the first tubular member is greater than or equal to 16.

146. An apparatus, comprising:

a plastically deformed and radially expanded tubular member having a first portion having a first outside diameter and a remaining portion having a second outside diameter;

wherein the ratio of the original outside diameter  $OD_0$  of the first tubular member to the original wall thickness  $t_0$  of the first tubular member is greater than or equal to 16.

147. An apparatus, comprising:

a plastically deformed and radially expanded first tubular member having a first portion having a first outside diameter and a remaining portion having a second outside diameter; and

a plastically deformed and radially expanded second tubular member coupled to the first portion of the first tubular member;

wherein the ratio of the original outside diameter  $OD_0$  of the first tubular member to the original wall thickness  $t_0$  of the first tubular member is greater than or equal to 16.

148. The apparatus of claim 147, wherein the inside diameters of the first and second tubular members are substantially equal.

149. A wellbore casing formed in a wellbore, comprising:

a plastically deformed and radially expanded first tubular member having a first portion having a first outside diameter and a remaining portion having a second outside diameter; and

a plastically deformed and radially expanded second tubular member coupled to the first portion of the first tubular member;